



OVERVIEW OF THE MODULES FOR BUILDING A WIRELESS SENSOR NETWORK

Daniel R. Denev

*KONSTANTIN PRESLOVSKI UNIVERSITY OF SHUMEN, 115 UNIVERSITETSKA,
SHUMEN 9700,
E-mail: slimshady33@abv.bg*

ABSTRACT: *Recent technological advances have enabled the development of low-cost, low-power and multifunctional sensor devices. These nodes are autonomous devices with integrated sensing, processing, and communication capabilities. A sensor is an electronic device that is capable of detecting environmental conditions such as temperature, sound, chemicals, or the presence of certain objects. Sensors are generally equipped with data processing and communication capabilities. The sensing circuitry measures parameters from the environment surrounding the sensor and transforms them into electric signals*

KEY WORDS: *Gateways, System control, Wireless sensor motes*

1. Introduction

The current generation of interactive devices and networks is developing a wide class of interactives everywhere in computer applications. The current trend to integrate wireless networking into interactive devices such as PDAs, cell phones, and laptops is leading to the availability of information such as news, merchandise receipts, well-known services such as e-mail, appointment tracking, and multimedia content from anywhere, anytime. These applications have significantly proven workplace productivity despite the fact that human participation is often required in the computational cycle. These applications are traditionally interacting with virtual content such as: e-mail, financial reporting and text documents.

Today, millions of sensors are scattered in both industrial and non-industrial office environments. These sensors include monitoring devices (HVAC) such as thermometers, barometers, humidity measures, monitoring, carbon monoxide,

smoke detectors, access control, glass detectors, access control to RFID badge readers. In most cases, the sensors are used for a specific application and access to the sensor output only locally (locally).

One usually has to go to the sensor to get the current information. In some cases, the sensors may be located near a closed loop of the monitoring station, but these monitoring stations are of general application. While these sensors serve the useful purposes of those who are located next to them, in practice each sensor is used for one monitored application [2, 5].

Through the network, these devices provide access to remote information and enable opportunities for many new applications that are coming out. The advent of low-cost, low-power wireless sensors, and automatically configurable network technologies, allow sensors to be easily located anywhere, ad-hoc. These interface installations for physical work and the promise to make everyday tasks easier, to increase our ability to optimize the environment in which we live and work. Recent advances in sensor hardware make it possible to deploy small sensors in an office environment, but many challenges remain.

Two cases are considered in detail to explore these challenges: an application to assist workers, to find conference rooms, and others to guide visitors around the office environment. In addition to the challenges shown, in the development and evaluation of real applications, these applications illustrate the issues that are of paramount importance for the office environment. For a conference room, applications must be integrated with existing network and sensor infrastructures and interact with users in an appropriate way. Visitor applications should contain a restriction on human movement and be easy to deploy and maintain.

In addition, both applications contain automatically configurable wireless networks and low-power operations (as many other touch applications do). These requirements can be surprising in building an application where power and network are both relatively significant. However, sensors cannot always be located near powerful or networked objects.

Additional cabling can quickly outweigh the costs and benefits of ad-hoc applications. Even in new designs, each wired network port or outlet has a price that must be justified. Thus, we see low-power, energy-saving operations as wireless needs even in relatively wired environments. However, there is an opportunity, through leverage, for these infrastructural resources available to support the entire network. We briefly look at the hardware that can be used in the workplace.

2. Hardware for the located sensor network of the workplace

Four types of hardware platforms with diverse capabilities are often used to deploy sensor network applications in the workplace: sensor modules, display modules, gateways, and handheld units. These hardware platforms are adapted for perception, from human interaction with the sensor network and with the workplace networks, and they thus provide a combination of power and processing of input-output capabilities. Each constructed hardware block described in this section should be considered as an indicative class of devices.

Sensor modules

The particle is a sensor with a widely applicable platform that combines sensitivity, computation and communication. The particles are usually low cost, small, battery powered devices that are designed to be able to place large-scale sensors in the environment. An example of Berkeley (Fig. 1), which is commonly used in the sensor network for the study and application of Mica-2. The Mica-2 mote is designed using components and includes an input-output connector to provide stacked platforms for effective integration with sensors and alternative communication boards for experiment [3, 4].



Fig. 1. Sensor modules

Screen module

The Mica-2 optimizes power consumption, cost and size, and is designed primarily for manually limited amounts of data from simple sensors and is not suitable for many sensor network applications that require high-bandwidth data collection, such as sound and image vibration. Intel mote is increasing processing capacity to provide an example of a device that can be used to more sensitive broadband-intensive data and perform on stable network communication. Many of the workplace applications described in this article use sensor modules.

While the button is useful in many applications, the more expensive interface is sometimes preferred. The LCD screen module (Fig. 2) is a small, low-power clock-shaped module designed to limit human interaction with the sensor

network. This device consists of a Mica-2 integrated with an LCD capable of displaying text and simple graphics and four control buttons. These buttons can be used to activate the wake-up module from "Deep sleep" and also allow the user to enter text. These devices provide an easy and inexpensive way to spread the screen and the user to interact with information in the workplace [1, 3].



Fig. 2. LCD module

Portable modules

Although suitable for limited interactions, handheld devices such as PDAs and laptops can provide a sophisticated user interface and tools for analyzing data for humans as well. CANBY (Fig. 3) is a compact flash card format is the reason for the Mica-2 mote by allowing pockets and laptops to easily interact with sensor networks. These devices can be used as part of a field tool. Example Field tool Task allows it to be manually used to interrogators near the person by sending "ping" messages to the corresponding module. In some working applications, the GUIs of the handheld module have been used to provide information from sensors that are close to the person.



Fig. 3. Portable module

Gateway type modules

The described sensor modules minimize cost and size by eliminating traditional network support such as Ethernet or 802.11. Gateway modules are devices that can eliminate communication between sensor modules and higher

end wired and wireless networks. The gateway module often has more computing capabilities than the sensor modules and good access to limited power. An example of a Gateway module is the Stargate format (Fig. 4), which includes the 400 MHz Intel XScale™ architecture of the main processor, tens of megabytes of RAM and more gigabytes permanently stored.

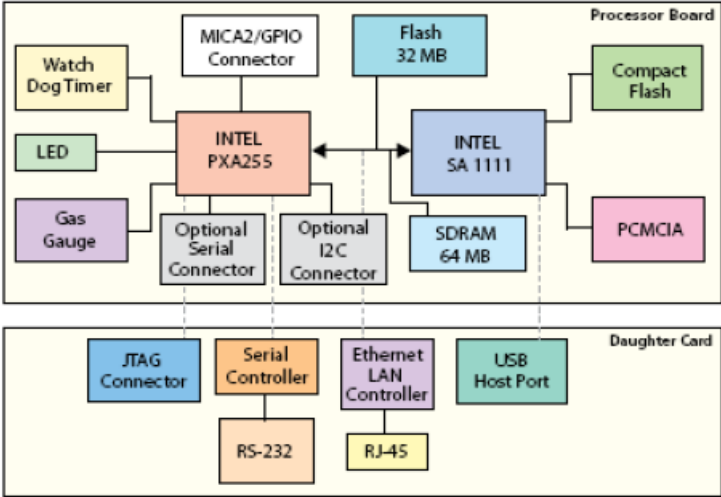

Fig. 4. Xscale architecture

It is possible from an interface directly to the Mica-2 or Intel mote device and can connect data from a low-power sensor network to traditional networks including 802.11, Ethernet as well as a wide area network. In addition, the processing and provisioning of memory in the stargate module allows it to work as a web interface to the sensor network. The reading sensor can be stored in a local database and in doubt on the Internet. However, the same Web interface can be used to activate and manage the sensor network. As described later in this chapter, stargate can create hierarchical networks by providing improved sensor network efficiency to reduce power consumption and extend battery life.

3. Wireless sensor applications

Sensor networks play an important role in the research community. Embedded computers are well established in our lives, in our homes and in our work environments. Embedded systems, by definition, affect the physical world. These sensors, actuators and controllers that are programmed to perform certain functions. As the range of applications grows the need for the network grows several embedded systems perform them increasingly complex tasks. The automotive field is an excellent example. Here are some embedded systems affecting safety, comfort in the driving experience. The advantage of sensor

networks is huge, the location and maintenance of a network of thousands of modules makes it impossible to contain thousands of miles of wire that is needed by the connections. The application in the various fields of research is being developed. Interesting ongoing projects include extensive experimentation with the structural response to earthquakes, habitat monitoring, intelligent transportation systems, and other important application fields include house and automatic construction and military applications. Automatically configurable, easy-to-deploy everywhere, intangible sensor networks are an ideal technology for intelligence and military attacks to detect enemy and artillery movement, and to monitor and manage resources.

4. Conclusion

While the specific work applications described above are of interest to specific users and industry, the techniques open to implementing and deploying this application are generally useful for the ability of a wide range of workplace applications. Routing algorithms, simple networks and easily configured are specific technologies, all that makes sensor networks in application building. A key challenge for the sensor network is to prove that the working application has a return on investment, through ease of use, easy management and operational productivity.

Reference:

- [1]. Arnstein L., Borriello G., Consolvo S., Hung C., Su J. Labscape: A Smart Environment for the Cell Biology Laboratory. IEEE Pervasive Computing Magazine, vol. 1, no. 3, New York, NY, July-September 2002, pp. 13-21.
- [2]. Konstantinova E., Tsankov Ts. Analyzing security threats in smart homes technology. International Scientific Conference “Defense Technologies” DefTech 2020, Faculty of Artillery, Air Defense and Communication and Information Systems, Shumen, 2020, ISSN 2367-7902.
- [3]. Lalev H., Tsankov Ts., Nikolov I. IP management of technology projects. Scientific Conference with international participation MATTEH 2010, Shumen, 2010, ISSN 1314-3921.
- [4]. Perkins E.C., Bhagwat P. Highly dynamic Destination-Sequenced Distance-Vector Routing (DSDV) for Mobile Computers. Proceedings of the Conference on Communications Architectures, Protocols and Applications, London, UK, August 1994, pp. 234-244.
- [5]. TASK TinyOS Toolkit <http://berkeley.intel-research.net/task/>